

Reflectix® Insulation

Solutions for the Contractor



Providing the Contractor with the Most Accurate and Useful Information on
the Thermal Performance of Reflective Insulations and System R-values



Reflectix goes the extra mile to provide you with accurate information

Over the years, Reflectix has collected and continues to collect test data on the more popular applications using our insulation products. This brochure is the culmination of that research. On the following pages, we will discuss many of these applications in detail including their R-values, additional benefits and installation procedures.

Through the use of independent certified labs and government approved laboratories, Reflectix conducted tests on complete wall, floor, pipe and duct assemblies insulated with Reflectix®. These tests have enabled us to provide you with the most accurate and useful information possible on thermal performance or system R-values.

System R-values report the thermal resistance of complete assemblies, including insulation, studs, floor joists, furring strips and any other building materials a particular application may involve.

If you have questions on a specific application, call our toll free number today, 1-800-879-3645 or visit our website at www.reflectixinc.com.

**Reflectix® Insulation.
It Works! It's Just That Simple.**

What is Reflectix® Insulation?



Reflectix® is a 5/16" thick, seven layer, reflective insulation which is available in rolls of various widths and lengths. It is used extensively in both specialty and standard construction projects. Two outer layers of aluminum foil reflect 97% of

radiant heat. Each layer of foil is bonded to a tough layer of polyethylene for strength. Two inner layers of insulating bubbles resist conductive heat flow, while a center layer of polyethylene gives Reflectix® high reliability and strength.

Reflectix® provides single bubble, double bubble, standard edge and staple tabbed product lines and is ideal for new construction or retrofit of existing structures.

HOW DOES IT WORK?

Radiant heat, the major source of heat flow, is energy in the form of infrared waves. It travels at the speed of light, even through a vacuum, and is either transmitted through, absorbed into, or reflected by any material it contacts. Air, water and glass, for example, transmit visible light in varying degrees. A white surface, such as snow, reflects it; and a black surface absorbs it. Reflectix® Insulation reflects up to 97% of the radiant energy striking its surface. Illustrations below: Reflectix® reflects sun's rays in the hot summer months yet retains interior heat and helps eliminate potentially damaging ice dams during the winter months.

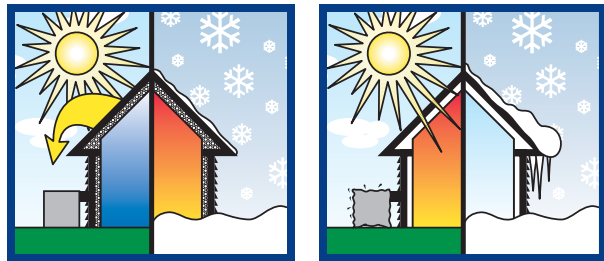

TABLE OF CONTENTS

WHAT IS REFLECTIX®? / ABOUT R-VALUES	2
CRAWL SPACE APPLICATION / INSTALLATION	3
ATTIC APPLICATION / INSTALLATION	4
SIDE WALL APPLICATION / INSTALLATION	5
MASONRY WALL APPLICATION / INSTALLATION	6
RADIANT FLOOR APPLICATIONS / INSTALLATIONS	7-8
PLUMBING/HVAC APPLICATIONS / INSTALLATIONS	9
BLACK-GLOBE EFFECT / RADIANT HEAT TRANSFER	10
POST FRAME NEW CONSTRUCTION	11-12
POST FRAME RETROFIT	13
REFLECTIX® SAFETY TIPS	13
METAL BUILDING NEW CONSTRUCTION	14
METAL BUILDING RETROFIT	15
REFLECTIX® TAPING TIPS	15
BENEFITS OF USING REFLECTIX®	16
TESTING AND CERTIFICATION	17
ENERGY STAR® HOME SEALING	18

About R-Values

Most insulation companies do not test beyond a product R-value, which is the thermal resistance of the product only. For a reflective insulation to be most effective, it must be installed with airspaces. The thermal value of the insulation system will vary depending on the size of the airspaces and the direction of heat flow. This is why with one basic product, we can achieve several different R-values. The system R-values provide you with a more accurate performance report of our product. You can feel confident on your next job specifying Reflectix® Insulation, knowing that we've left nothing to question.

Reflectix® also has an extensive bank of testing for fire safety, vapor transmission, mold and mildew resistance, emittance and smoke density, along with a full line of physical properties tests. Our products and applications have been evaluated by an impressive and ever growing list of agencies including: BOCA, ICBO, SBCCI, CCMC,* and the states of California, Wisconsin, and Minnesota.

R-16.8?

R-5.6?

R-16.8?

* BOCA: Building Officials and Code Administrators; ICBO: International Conference of Building Officials; SBCCI: Southern Building Code Congress International; CCMC: Canadian Construction Materials Centre

R-16.8

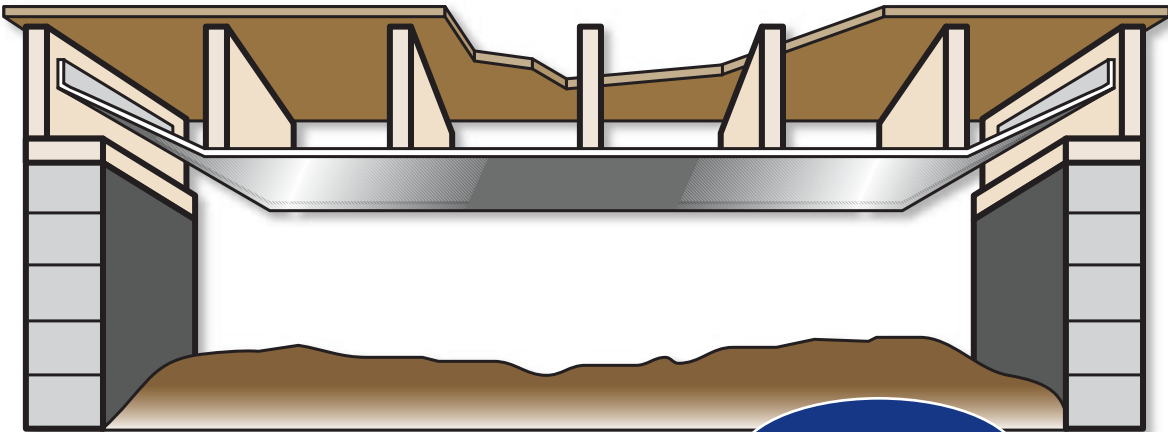

A RADON AND VAPOR RETARDER!

Crawl Space Application



When Reflectix® is installed in crawl spaces, the heat rays which flow downward in winter are reflected upward, back into the home at a 97% rate. The temperature of the cold floors which cause cold feet will be raised while fuel bills reduce, providing for

INCREASED COMFORT. As the heat is reflected back into the living area, it warms other objects. Those objects radiate heat back into the room, increasing your living comfort.

floor joist. Overlap tabs and seal with Reflectix® Foil Tape to create a vapor barrier. At the ends, staple up to the sub-floor or band board.

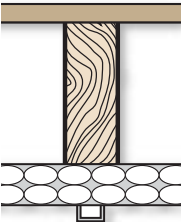
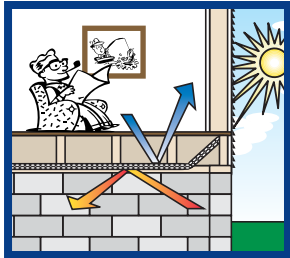
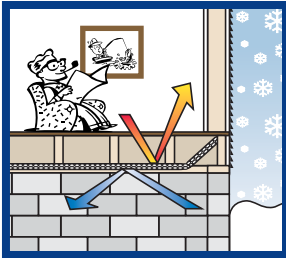

CRAWL SPACE INSTALLATION

- 1) Inspect your crawl space and make any needed repairs before installing Reflectix®.
- 2) Check your crawl space to determine whether your floor joists are 16" or 24" on-center.
- 3) Determine if there are water pipes and heating ducts which hang below the floor joists. These will need to be insulated. Reflectix® Pipe Wrap and Duct Insulation are designed especially for this use. There is no need to wrap water pipes or duct work that fall between floor joists. Reflectix® will provide adequate insulating without extra wrapping.
- 4) Start at the end of the house and face staple Reflectix® to the bottom of the first floor joist. Leave enough length so the insulation can be pulled up to the band board and stapled.
- 5) Start the next run and face staple to the bottom of the

CONSTRUCTION

Installed on the bottom of 2" x 10", 16" on-center floor joists. Heat flows downward.

Construction Components:	R-Values:	
	At Framing	At Cavity
Inside Air Film92	.92
3/4" Wood Subfloor75	.75
5/8" Partical Board Underlayment82	.82
2"x 10" Wood Floor Joist 16" OC	10.07	---
9.5" Airspace	---	9.40
Bubble Pack	1.10	1.10
Outside Air Film	4.55	4.55
TOTAL	18.21	17.54

Total Design "U" = .20/18.21 + .80/17.54 = .0566
 Total Design "R" = 1/.0566 = 17.67

Note: The above assembly R-Value of 16.8 includes a 4.55 value for a reflective air film.

REFLECTS 97%
RADIANT HEAT

Attic Application



Much of the heat entering your home comes through the roof. Adding Reflectix® in your attic helps to keep your house cooler in the summer. Reflectix® is an ideal radiant barrier to supplement the insulation already in your attic. Consider our 16"

or 24" on-center rolls when insulating your attic.

ATTIC INSTALLATION NEW CONSTRUCTION / RETROFIT

- 1) Check the area you are insulating and make any needed repairs before installing Reflectix®.
- 2) Unroll the Reflectix® as you work, and cut it to suitable lengths with scissors or utility knife.
- 3) Allow for proper ventilation. (See note above on ventilation.)
- 4) Staple Reflectix® to the undersides of exposed rafters or between the trusses.

What about R-Values? Reflectix® performs as a radiant barrier in this use rather than as an insulation. Therefore, we make no R-Value claims for this application.

Ventilation: Good ventilation in your attic increases your comfort and helps the materials of your house last longer. Be sure not to block ventilation paths when you install Reflectix®.

Accept No
Substitutes!



EASY TO USE STAPLE TAB!

Non-tabbed bubble/foil insulations **DO NOT** easily or accurately bend to achieve the necessary 3/4" airspace.

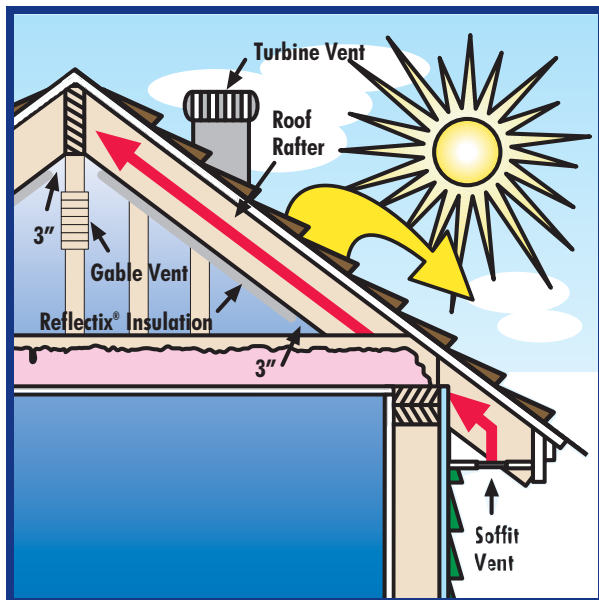

Above: Reflectix® attic application with a turbine or gable vent. A 3" gap along the ridge pole and at the base of the rafters (soffit) ensures enough air flow between Reflectix® and the roof deck. This applies to all vent systems other than soffit and ridge.

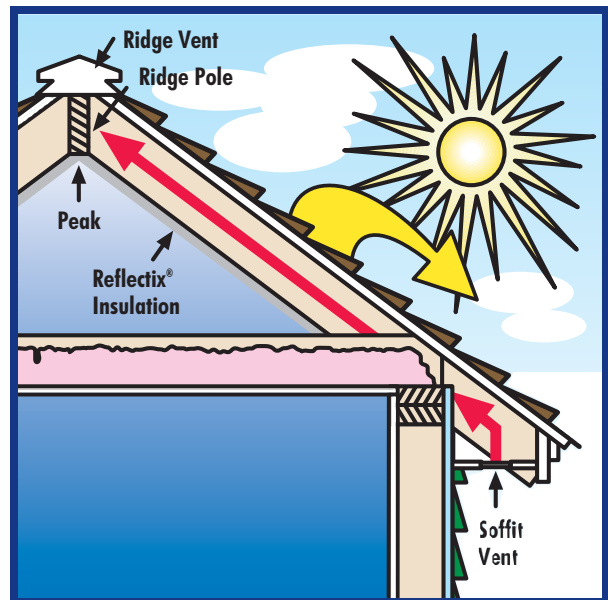

Above: Reflectix® attic application with a soffit and ridge vent system. Install Reflectix® clear to ridge pole.

R-19.56

Side Wall Application



This application utilizes the properties of both mass insulation and Reflectix® giving a superior system R-value of R-19.56. This application consists of Reflectix® Insulation, mass insulation and rigid board. This assembly was developed to meet building codes while keeping framing costs down.

SIDE WALL INSTALLATION

- 1) With a conventional 2" x 4" wall, we recommend an R-12 (2.1 RSI) friction fit fiberglass batt and exterior 1/2" rigid board. Nail the 1" x 2" furring strips across the studs every 16".
- 2) Staple Reflectix® Insulation to the furring strips using 5/16" staples. Tape all seams using Reflectix® Foil Tape.
- 3) Nail a second set of 1" x 2" furring strips directly over the first set of furring strips using three #10 wood screws.
- 4) Apply sheet rock to the furring strips using sheet rock screws.
- 5) In this application, Reflectix® becomes the vapor retarder as well as an insulator.
- 6) A helpful hint... Use shallow electric boxes and install them in the last set of furring strips, then the vapor retarder will remain intact.

ALTERNATE SIDE WALL APPLICATION USING REFLECTIX® STAPLE TAB

Many U.S. contractors utilize Reflectix® Staple Tab Insulation in a 2" x 6" side wall cavity to avoid the application expense and labor of using furring strips. Roll widths are 16" and 24" on center for convenience and 48" rolls are also available.

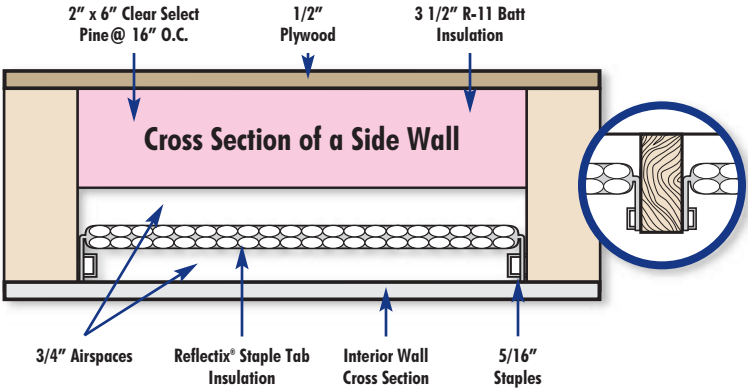

REFLECTIX® 2" x 4" INSULATED WALL SYSTEM

Report #: CCMC 12342-R

**R-18.1
3.19 RSI**

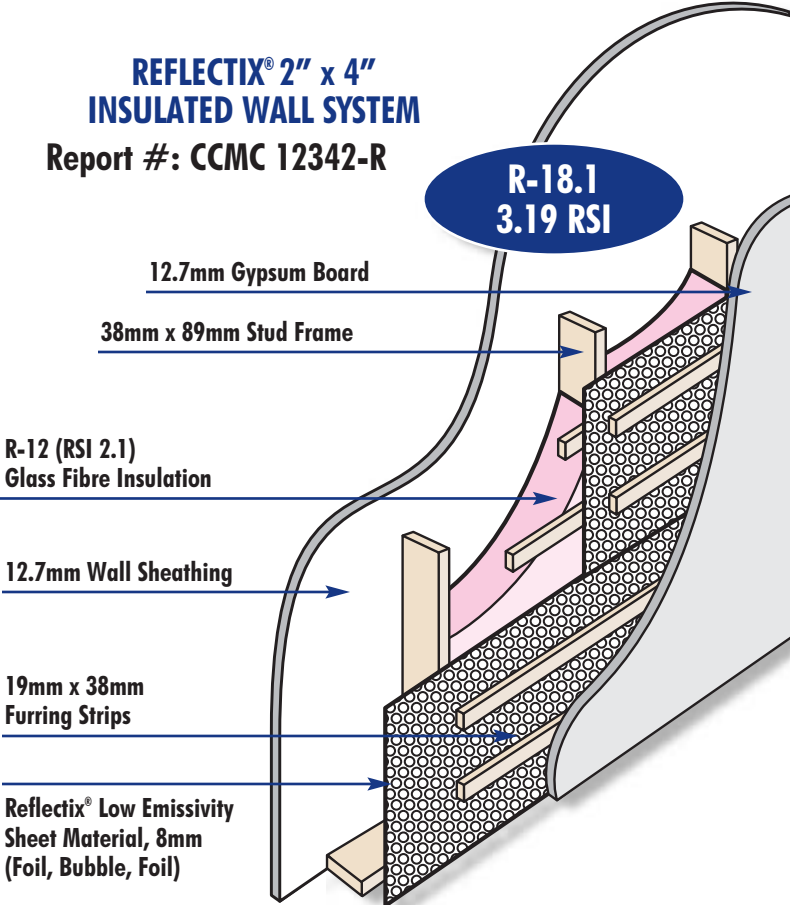

CONSTRUCTION		
Construction Components:	R-Values:	
	At Framing	At Cavity
Air Film17	.17
1/2" Plywood62	.62
2" x 6" Stud	6.88	---
3.5" Fiberglass	---	R-12 (2RSI)
Reflectix® and Airspaces	---	R-4.54 (0.80)
1/2" Gypsum Board45	.45
Inside Air Film68	.68
TOTAL	8.8	18.46
Total Design "U" = .20/8.8 + .80/18.46 = .0661		
Total Design "R" = 1/.0661 = 15.14		

R-4.24
WITH 2" X 2" FURRING

Masonry/Basement Wall Application



R-3.30
1" X 2" FURRING

Reflectix® is great as a basement wall insulator. Reflectix® performs as a vapor retarder, resists fungus and mold, and also controls dew point problems. R-Value is unaffected by a damp basement environment. The tested R-Value is obtained by

installing Reflectix® as instructed; between two furring strips creating an air space on both sides of the product.

MASONRY WALL INSTALLATION

- 1) Check the area you are insulating and make any needed repairs before installing Reflectix®.
- 2) Use adhesive caulk or nails to attach furring strips to the wall 16" or 24" on-center. Use small pieces of tape to hold the strips against the wall until the caulk has thoroughly cured.
- 3) Using Reflectix® Insulation, simply install between furring strips. Staples should be placed every 3" to 4". **White poly should face the interior of the building.**
- 4) Be sure at least a 1/2" air space is maintained between the Reflectix® foil surface—such as your basement wall. This will give you the maximum protection and insulation values.

Note: When using one set of furring strips, Reflectix recommends installing our Single Bubble White Poly product. When your installation requires two sets of furring strips, our Double Bubble product with foil on both sides is recommended.

DID YOU KNOW FACTS ABOUT REFLECTIX®

- Unlike standard insulation, aluminum has a natural ability to reflect heat while common insulation merely absorbs it. Reflectix® is a flexible and extremely versatile product that can be used in non-traditional applications.
- Reflective insulation was used in experiments aboard the space shuttle.
- Reflectix® maintains a constant R-Value between temperature ranges of -60° to 180°F.
- Reflectix® Insulation inhibits or eliminates condensation.
- Reflectix® Insulation provides an efficient, effective space saving method of temperature control.
- Non-toxic and non-carcinogenic; Reflectix® products are environmentally friendly. They require no respirators or protective clothing.
- When installed in your attic, Reflectix® Insulation acts as a radiant barrier. It keeps your house cooler in the summer and saves energy.
- Reflectix® Insulation comes packaged for crawl spaces, basement walls, ducts, pipes, water heaters and other specialty applications.
- Cold floors? Reflectix® Insulation in a crawl space will save money on heating costs and provide warmer floors at the same time.

CONSTRUCTION

Reflectix® installed with 1" x 2" furring strips, 16" on-center to block or concrete walls. Heat flows horizontally.

Construction Components:	R-Values:	
	At Framing	At Cavity
Inside Air Film68	.68
1/2" Plaster Board45	.45
Reflectix® Insulation	---	*3.30
Furring Strips	1.59	1.59
8" Concrete Block	1.11	1.11
TOTAL	3.83	7.13

Total Design "U" = .20/3.83 + .80/7.13 = .1753
Total Design "R" = 1/.1478 = 5.70

** Includes the thermal resistance for Reflectix® Insulation and the airspaces on either side of the product.*

Radiant Floor Applications

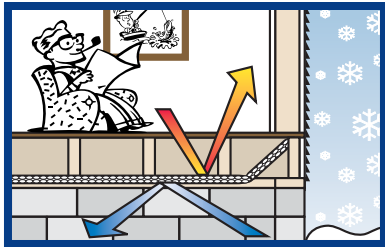

Radiant Floor Heating is not a new concept. Centuries ago the Romans forced hot air under the floors of their housing structures. Also,

architect Frank Lloyd Wright ran hot water pipes throughout the floors of his many structures back in the 1930's. In fact, this application is so common in Europe over 50% of all newly constructed buildings are equipped with a radiant floor heating system.

Radiant heating provides **whole floor comfort**, quiet operation, eliminates drafts and dust problems from forced air and is invisible (no registers or radiators.)

Reflectix® is a great enhancement to any radiant floor heat-

ing application. It reflects 97% of the radiant energy striking its surface – **keeping your feet and floor comfortable**. Reflectix® is tough yet pliable, easy to install, radiates heat in desired direction, is an excellent vapor retarder and increases efficiency in heating. Reflectix® crush resistance is 60 psi.

REFLECTIX® USED IN SNOW MELTING

Use Reflectix® to insulate your next snow melt system. Snow melt systems provide for improved safety for patrons walking in ice and snow. These systems require less maintenance – no salting or shoveling. Pavement will last longer without the use of harsh chemicals to melt the snow and ice. Snow melt systems are used in several applications; driveways, walkways, hospital emergency room entrances, handicap access ramps, parking lots, loading docks, etc. No more snow removal!

UNDER OR BETWEEN WOOD JOISTS

METHOD 1: USING STANDARD EDGE MATERIAL

- 1) Unroll and staple Reflectix® Standard Edge under floor joists.
- 2) Seal the joints and outer edges with Reflectix® Foil Tape.

METHOD 2: USING STAPLE TAB MATERIAL

- 1) Using Reflectix® Staple Tab Insulation, install the insulation between the floor joists. Allow 4" - 6" below the heating coils or as recommended by manufacturer instruction.
- 2) Staple into joists as shown in illustration.
- 3) Seal ends using Reflectix® Foil Tape.

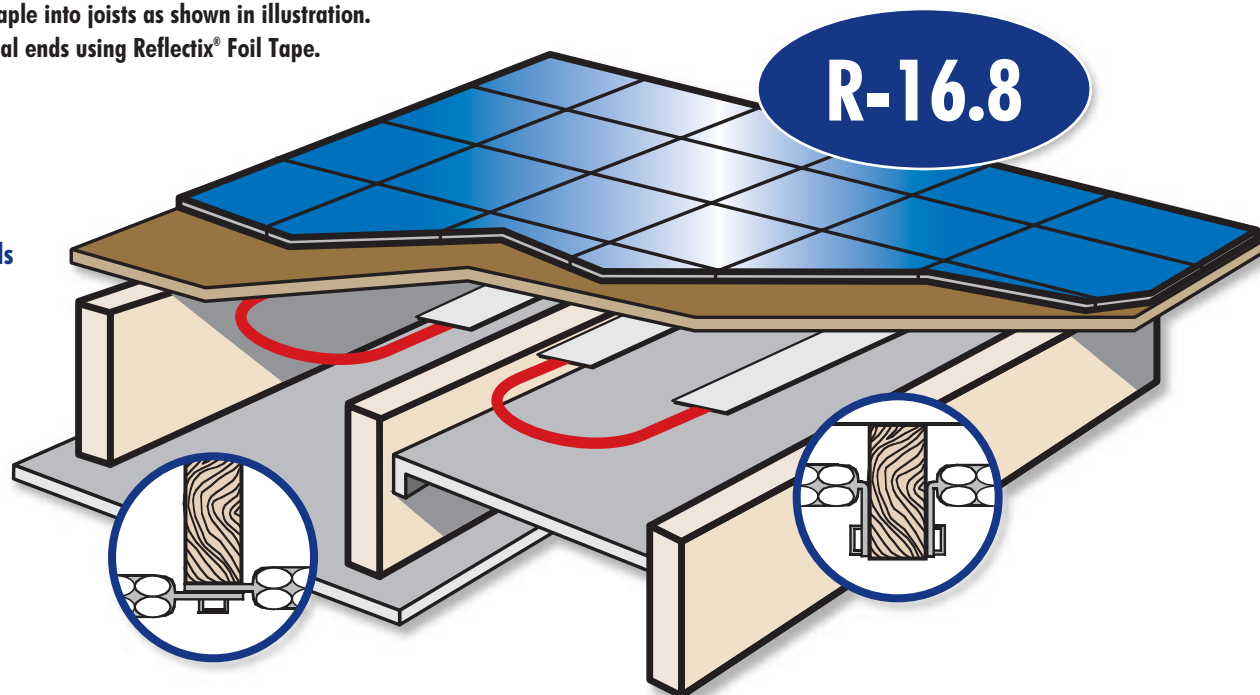

Two installation methods highlighted in circles below: Radiant heating under or between wood joists

IN A CONCRETE FLOOR

USING CONCRETE PAD MATERIAL

- 1) Unroll Reflectix® Concrete Pad over the sand or gravel, aluminum side facing the ground (white poly side up.)
- 2) Butt the seams.
- 3) Seal the seams with 2" wide poly tape. All tape should be applied using a flat edge taping tool to assure good adhesion.
- 4) Install radiant heating and then pour the concrete as usual.

Builder's Note: Adding 1" of sand over the Reflectix® Concrete Pad will facilitate water drainage and shorten the actual curing time.

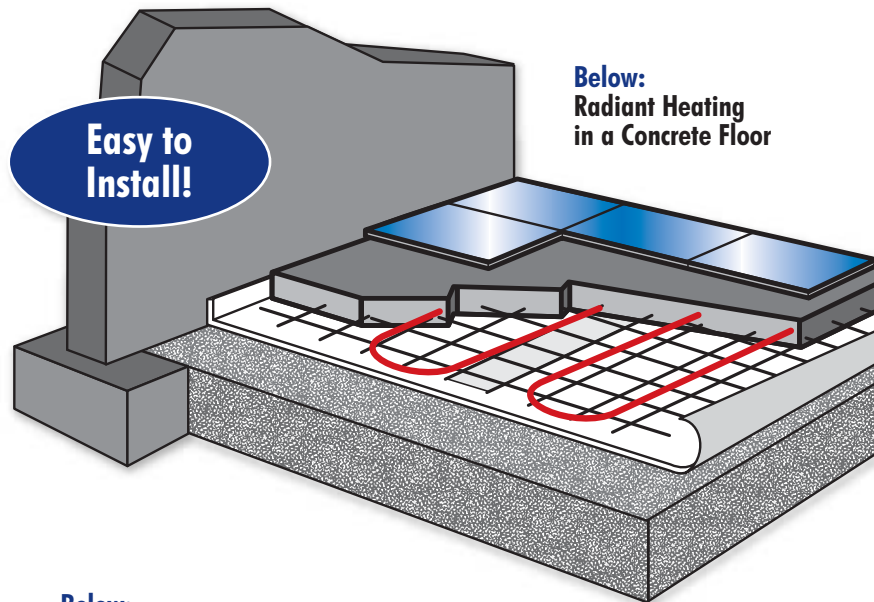

OVER WOOD OR EXISTING FLOOR

USING CONCRETE PAD MATERIAL

- 1) Unroll Reflectix® Concrete Pad over existing wood floor with aluminum side facing down (white poly side up.) Cut material to be flush with walls.
- 2) Butt the seams.
- 3) Seal the seams with 2" wide poly tape. All tape should be applied using a flat edge taping tool to assure good adhesion.
- 4) Install radiant heating then pour concrete over the white poly as usual.

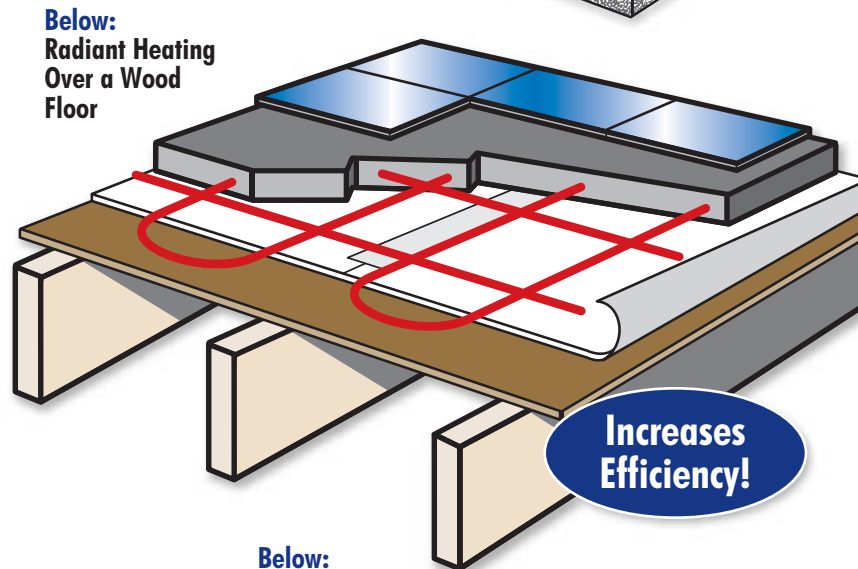

IN A SUBFLOOR

USING DOUBLE BUBBLE WHITE (DBW) MATERIAL

- 1) Unroll Reflectix® Double Bubble White (DBW) over existing floor with material to be flush with walls (foil facing up.)
- 2) Butt the seams.
- 3) Seal the seams with 2" wide foil tape. Tape should be applied using a flat edge taping tool to assure good adhesion.
- 4) Install sleepers.
- 5) Install floor.

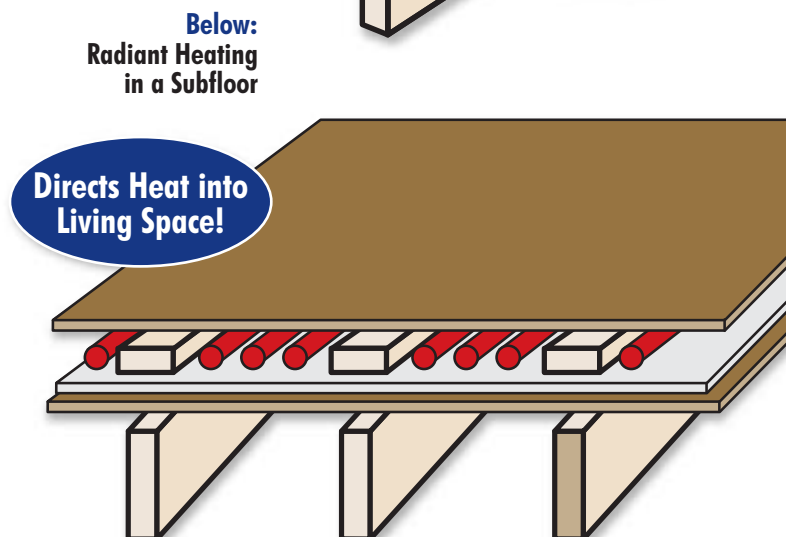

Plumbing and HVAC Applications

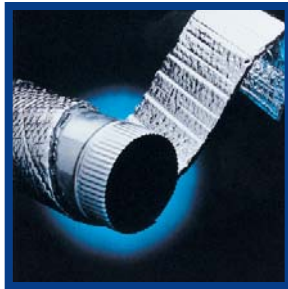
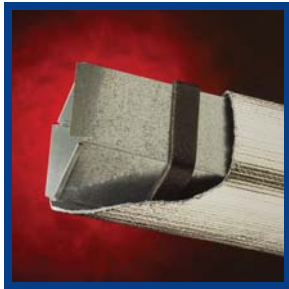

**ELIMINATE
HEAT LOSS!**

DUCT INSULATION - R-6 *(Illustration to the right)*

Energy costs can be greatly reduced by wrapping ducts with Reflectix® virtually eliminating unnecessary heat loss, gain and air leakage. Reflectix® also helps to ensure consistent temperatures.

- 1) Secure spacers every 24" to 36" around ducting, fastening the spacers with UL181 approved HVAC foil tape. This will provide the necessary air space for the most effective use of Reflectix®. Reflectix® spacer product is recommended.
- 2) Reflectix® Standard Edge material can then be cut to the proper size and wrapped around the duct.
- 3) Tape all seams with UL181 approved HVAC foil tape.

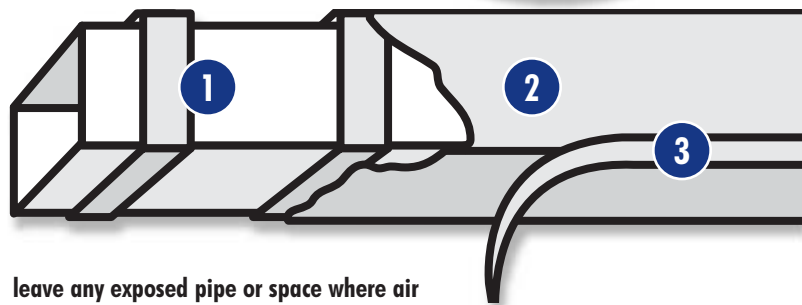

leave any exposed pipe or space where air can enter between the pipe and the wrap.

Note: In humid regions, Reflectix recommends wrapping the duct with spacer strips before applying the insulation.

SPIRAL DUCT INSULATION - R-4

Simply spiral around the duct, overlapping 1" as you go. Do not leave any open air space or exposed duct. Fasten each end of Reflectix® to the duct using UL181 approved HVAC foil tape.

LINEAR PIPE WRAP - R-4

To help reduce condensation on cold pipes and heat loss on hot pipes, wrap them with Reflectix® Insulation.

Cut a length of pipe wrap from the roll that will be easy to handle in your working area. Place the white side of the insulation next to the pipe. Pre-shape the insulation by wrapping it around the pipe. This will make the taping easier and help to form a better seal. Remove the protective backing from the tape and overlap the edge so it just covers the tape area. On small pipes this will produce a loose fit and on larger pipes, a snug fit. Insulation value is not affected by a loose or tight fit.

SPIRAL PIPE WRAP - R-4

Simply spiral Reflectix® Pipe Wrap around your pipes, overlapping 1/2" as you go. Securely tape with Reflectix® Foil Tape around each end of your wrapped product. This procedure provides an air space that will aid the insulation value. Do not

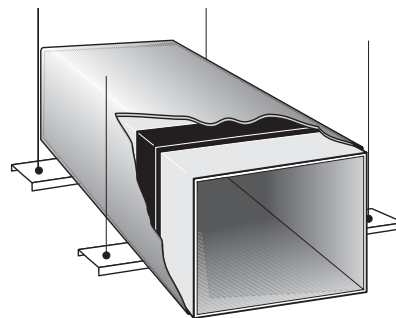

Shown to the left:
A Rectangular Duct
with a Saddle Hanger

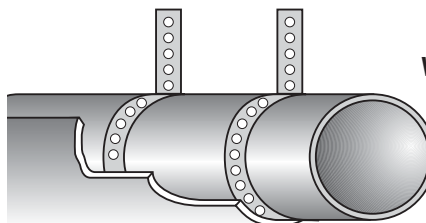

Shown to the left:
A Round Duct with a
Wire or Strap Hanger

Reflectix® Insulation and the Black Globe Effect

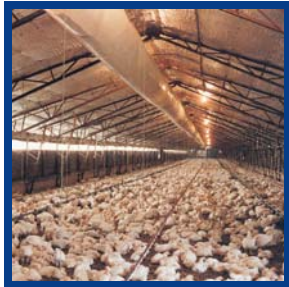

A little known natural phenomenon called the “black-globe effect” has a pronounced stress factor relating to the cost efficiency (or inefficiency) of weight gain in meat producing animals and birds. Whether an animal is outdoors or indoors, in temperatures exceeding 78° F, it absorbs a tremendous increase in radiant energy from the sun. Although the animal may be confined to a building, the “black-globe effect” on the animal is the same as if it were actually 10 to 20° F higher than air temperature. Studies show that with the elimination of the “black-globe effect” through the use of reflective foil insulation, many improvements are immediately apparent. In the dairy industry, an increase of

as much as 10% in milk production has been noted. Also noted; a conception rate improvement of nearly 24%. Broiler house feed conversions went from averages of 2.3 to 2.8 lbs. of feed per lb. of bird to a much improved 1.99 feed conversion.

Many growers are finding that their animals grow faster and more efficiently after installing Reflectix®. Death losses from heat are greatly reduced. The illustration to the right shows how an animal is heated even though the air temperature may not rise much. In winter, indoor heat is reflected back into the living space to produce greater comfort and energy savings.

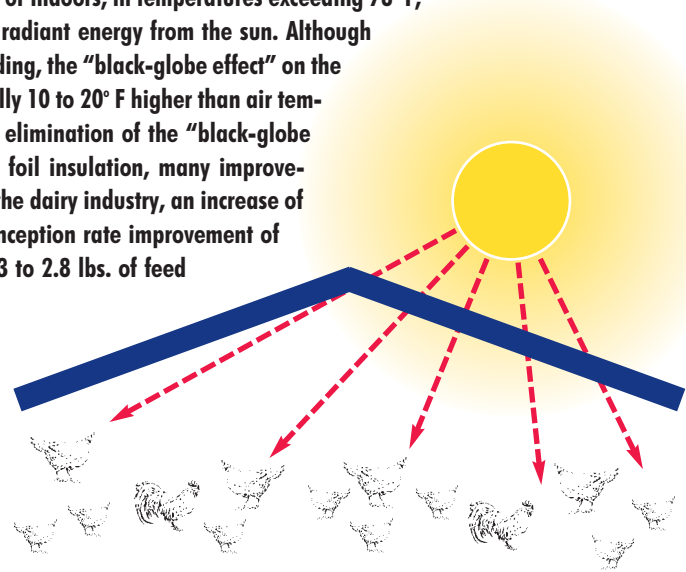

Reflectix® Insulation Blocks Radiant Heat Transfer

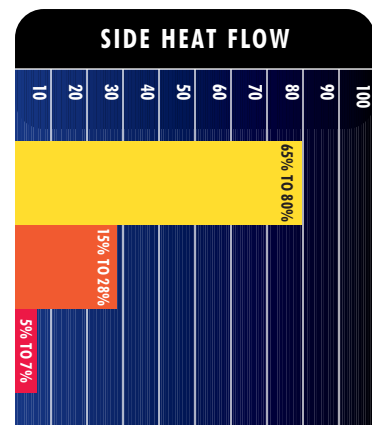
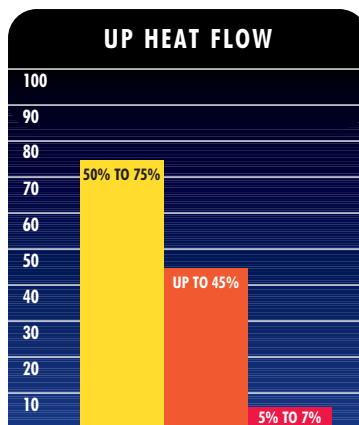
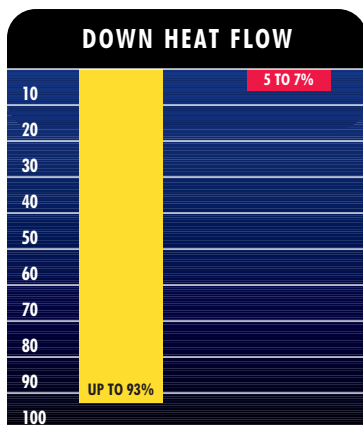

- Radiation
- Conduction
- Convection

According to an analysis performed at Penn State University, approximately 75% of total heat transfer in structures occurs through radiation. The foil in Reflectix® reflects 97% of the radiant energy striking it. An example of heat flow down is through the floor in the winter or through the attic in the summer. Heat flow up is through the ceiling in the winter. Heat flow side refers to heat loss through the walls.

Post Frame Construction

ROOF

The thermal values for roof applications in post frame construction were derived by testing an assembly consisting of a corrugated metal exterior, 2" x 4" purlins, Reflectix® Insulation, a 2" x 6" to represent the top cord of a truss, and 1/2" wafer board. The thermal values are for both exposed insulation and applications where the insulation is covered for fire codes.

THERMAL VALUES:

	Heat Flow Up	Heat Flow Down	U Value Up	U Value Down	K Value Up	K Value Down
Reflectix® w/ Wafer Board	6.93	15.11	.144	.066	.144	.066
Reflectix® w/ Metal Interior	6.22	14.40	.161	.069	.161	.069
Reflectix® Exposed to Interior	4.91*	12.81*	.204*	.078*	.204*	.078*

All thermal values are corrected for framing loss.

**Includes thermal resistance of 1.32 UP and 4.55 DOWN for interior air film.*

WALLS

The thermal values for Reflectix® installed in the walls of post frame buildings are based on testing of an assembly consisting of corrugated metal exterior, 2" x 4" girts, Reflectix® Insulation, a 4" x 6" to represent the support beam, and 1/2" wafer board as an interior wall covering.

THERMAL VALUES:

	Heat Flow Horiz.	U Value Horiz.	K Value Horiz.
Reflectix® w/ Wafer Board	6.93	.144	.144
Reflectix® w/ Metal Interior	6.22	.161	.161
Reflectix® Exposed to Interior	4.91*	.204*	.204*

All thermal values are corrected for framing loss.

**Includes thermal resistance of 1.70 for interior air film.*

Post Frame New Construction

ROOF INSTALLATION

- 1) After trusses are set, run two purlins to make sure the trusses are not pulled out of line.
- 2) Attach Reflectix® 48" Staple Tab Insulation to the first truss with at least 5/16" staples. Temporarily nail a 2" x 4" block to the truss to prevent foil from pulling away.
- 3) Roll out the Reflectix® across the trusses and pull the insulation tight.
- 4) Install purlins over insulation. Nail or screw to trusses through insulation.
- 5) Pull tabs up and run a bead of silicone between them, press together. When the silicone cures, there will be a permanent seam.*
- 6) Install the metal roof to purlins.

**Make sure that the silicone caulk is applied in a continuous bead with no breaks. Gaps will cause air infiltration which may cause condensation.*



WALL INSTALLATION

- 1) After main supports are installed, staple Reflectix® 48" Staple Tab Insulation horizontally to the support beams.
- 2) Fold tabs out and apply a bead of pure silicone caulk in the seam and press the tabs together.*
- 3) Install the 2" x 4" girts and the exterior corrugated metal.
- 4) From inside the building, staple insulation to the girts.
- 5) If an interior covering is called for, install either metal or wood sheets to the inside of the support beams. This will provide a 1 1/2" nominal airspace between the exterior metal and the insulation and a 5 1/4" nominal airspace between the insulation and the interior wall material.

**Make sure that the silicone caulk is applied in a continuous bead with no breaks. Gaps will cause air infiltration which may cause condensation.*



Tabbing insulation



Foil insulation installed with a finishing ceiling



Shown above is Reflectix® Insulation positioned beside the exterior wall. Interior walls may then be finished or covered with other building materials with no decline in performance. This application is appropriate in warm and hot weather climates.



Shown above is Reflectix® Insulation in a side wall application positioned to the interior. This application is correct in areas experiencing colder climates.

Post Frame Retrofit

ROOF INSTALLATION / BOTTOM OF PURLINS

- 1) Inspect the roof area for clutter in buildings where there is no ceiling.
- 2) Measure the distance between the trusses. Many times, the distance will be 4' or less. In some geographic areas, due to snow load, the distance will be as close as 2'.
- 3) Cut pieces of Reflectix® Insulation 6" longer than the distance between the ridge pole and the birds mouth.
- 4) Staple the insulation to the bottom of the purlins with 5/16" staples, 3" to 4" apart. Turn the edges down and staple to the side of the top cord of the trusses.
- 5) Staple the top of the insulation to the ridge pole and the bottom to the top plate at the wall.
- 6) Tape any butt seams with Reflectix® Foil Tape. Make sure the tape is applied so that a proper bond occurs.

ROOF INSTALLATION / ACROSS THE TRUSSES

- 1) Inspect the area above and directly below the bottom of the truss for clutter. Pay special attention to water lines above the truss. Water will freeze if left exposed above the insulation.
 - 2) Install 1" x 2" furring strips across the bottom cord of the trusses on 22" centers by nailing to the truss.
 - 3) Staple 48" Staple Tab Insulation to the furring strips, using 5/16" staples 3" to 4" apart.
 - 4) Turn the tabs down and run a bead of silicone caulk; press tabs together thereby creating a strong seal.*
 - 5) Tape any butt seams with Reflectix® Foil Tape. Make sure tape is applied so that a proper bond occurs.
- The Staple Tab and furring strip (22' on center) method for installation was designed for the bottom of the trusses. The furring strips run perpendicular to the trusses to compensate for any truss which may be unevenly spaced.

WALL INSTALLATION

Reflectix® can be installed either vertically or horizontally.

- 1) To install Reflectix® horizontally, staple the Standard Edge Insulation to the girts using 5/16" staples.
- 2) To install Reflectix® vertically, nail furring strips on 22" centers and staple Reflectix® 48" Staple Tab Insulation to the furring strips using 5/16" staples, 3" to 4" apart.
- 3) Turn the tabs out and use a pure silicone caulk to run a bead of caulk; press tabs together, thereby creating a strong seal.*

**Make sure that the silicone caulk is applied in a continuous bead with no breaks. Gaps will cause air infiltration which may cause condensation.*

CAUTION!

Safety Tips for Installing Reflectix® Insulation:

- **ALWAYS** CHECK LOCAL BUILDING CODES BEFORE INSTALLING REFLECTIX®.
- **ALWAYS** USE EYE PROTECTION WHEN USING STAPLE GUNS OR SCREW GUNS.
- **ALWAYS** EXERCISE CAUTION AROUND ELECTRICITY.
- **ALWAYS** CHECK THE AREA YOU ARE INSULATING AND MAKE ANY NEEDED REPAIRS BEFORE BEGINNING. ANY WORN WIRING SHOULD BE REPLACED BEFORE INSTALLING REFLECTIX®.
- REFLECTIX® WAS DESIGNED TO WORK BEST WHEN AN AIRSPACE OF 1/2" TO 3/4" HAS BEEN USED.
- MAKE SURE WORK AREA IS WELL VENTILATED AND WELL LIGHTED.
- WHEN WORKING WITH REFLECTIX® PRODUCTS OUTDOORS, WEAR SUN GLASSES.
- BE CAREFUL WHEN WORKING WITH LARGE PIECES OF REFLECTIX® ON WINDY DAYS.
- DO NOT WORK IN AREAS OF A BUILDING, SUCH AS THE ATTIC, WHEN TEMPERATURES ARE TOO HOT.

Metal Building New Construction

ROOF

The assembly used to test the thermal resistance of Reflectix® Insulation as it would be installed in new metal building construction consisted of a corrugated metal exterior, 1/2" extruded polystyrene thermal breaks 5' on center, Reflectix® Insulation, and 8" Z purlins commonly used in metal buildings.

THERMAL VALUES:

	Heat Flow Up	Heat Flow Down	U Value Up	U Value Down	K Value Up	K Value Down
Reflectix® w/ Wafer Board	5.02	7.93	.199	.126	.199	.126
Reflectix® w/ Metal Interior	4.29	7.29	.233	.137	.233	.137
Reflectix® Exposed to Interior	3.63*	7.26*	.275*	.138*	.275*	.138*

*Includes thermal resistance of 1.32 UP and 4.55 DOWN for interior air film.

WALLS

Thermal assembly tested for thermal resistance of Reflectix® Insulation in the walls of metal buildings consisted of corrugated metal exterior, 1/2" extruded polystyrene thermal breaks, Reflectix® Insulation, 8" Z girts, and 1/2" wafer board to represent an interior finished wall.

THERMAL VALUES:

	Heat Flow Horiz.	U Value Horiz.	K Value Horiz.
Reflectix® w/ Wafer Board	5.45	.183	.183
Reflectix® w/ Metal Interior	4.77	.210	.210
Reflectix® Exposed to Interior	4.50*	.222*	.222*

*Includes thermal resistance of 1.70 for interior air film.

ROOF INSTALLATION

- 1) After the red metal is erected, install Reflectix® Staple Tab Insulation over the purlins by using 1/2" tec screws and screwing the foil to the purlins.
- 2) Fold the tabs together and apply a bead of silicone caulk between the tabs, press together to create a tight seal.*
- 3) Install at least a 1/2" thermal break. If installing a standing seam roof, use clips with thermal breaks.
- 4) Install roofing either by screwing corrugated metal through the thermal break and insulation to the purlin or install a standing roof seam.
- 5) If an interior finish is to be installed, attach to the bottom of the purlins. This will create a 1/2" airspace between the roofing and the insulation and an 8" airspace between the insulation and the interior finish.

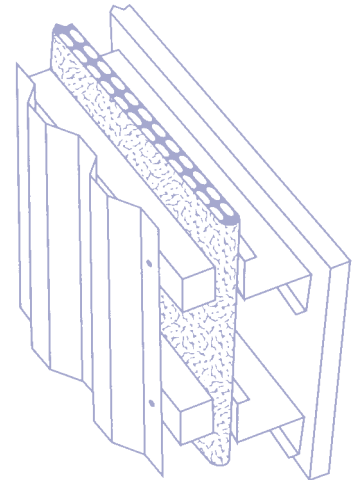

WALL INSTALLATION

- 1) Install Reflectix® Staple Tab Insulation vertically, using 1/2" tec screws to secure the insulation to the exterior of the C or Z purlins. Fold the tabs together and apply a bead of silicone caulk between the tabs, press together to create a tight seal.*
- 3) Install a 1/2" thermal break and attach corrugated metal to exterior finish.
- 4) If an interior finish is to be applied, install the interior face of the girts. This will create a 1/2" airspace between the exterior finish and the insulation and an 8" air space between the insulation and the interior finish.

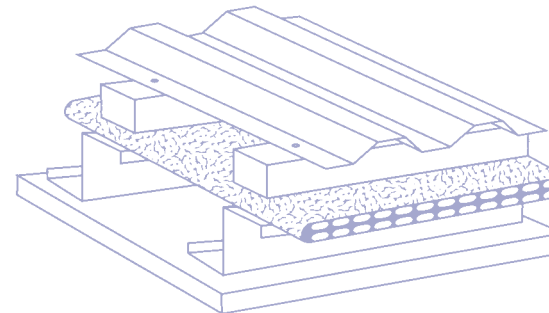

*Make sure that the silicone caulk is applied in a continuous bead with no breaks. Gaps will cause air infiltration which may cause condensation.

Metal Building Retrofit

ROOF INSTALLATION / BOTTOM OF PURLINS

Before installing Reflectix®, inspect the roof area for clutter—water sprinkler systems, conduit and lights. Sprinkler systems are especially important. All water pipes must be below the insulation to prevent the possibility of freezing in the winter. In many instances, the Reflectix® must be installed up near the roof deck.

- 1) Install 1" x 2" furring strips on the bottom of and perpendicular to the Z purlins on 22" centers. Use 1 1/4" self-taping sheet metal screws to secure the furring strips to the Z purlins.
- 2) Butt furring strips together and tape. Staple tape for reinforcement.
- 3) Use 48" wide Reflectix® Staple Tab Insulation and staple with tabs bent down.
- 4) There is no need to cut the Reflectix® Insulation to an exact size before installing, since the insulation is below the Z purlins.
- 5) Use a pure silicone caulk to run a bead of caulk down the tabs; press together. This will create a proper seal.*

**Make sure that the silicone caulk is applied in a continuous bead with no breaks. Gaps will cause air infiltration which may cause condensation.*

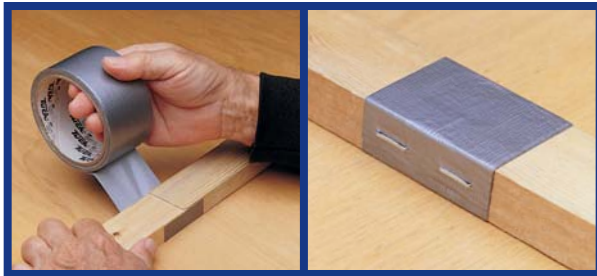

WALL INSTALLATION

The same pre-installation inspection must be made to insure a safe working environment.

- 1) Install furring strips to the Z purlins with 1 1/4" self-drilling screws on 22" centers.
- 2) Staple Reflectix® Insulation to the furring strips with 5/16" staples every 3" to 4".
- 3) Fold the tabs out and run a bead of pure silicone caulk down the tabs. Press the tabs together to create a proper seal.*

**Make sure that the silicone caulk is applied in a continuous bead with no breaks. Gaps will cause air infiltration which may cause condensation.*

CAUTION!



Our tape serves as the best means to join ends of Reflectix® together because it ensures a continuous reflective surface. The use of ordinary adhesive tape would create "windows" for radiant energy to pass through.

Reflectix® Insulation Taping Tips:

- **NEVER USE DUCT TAPE.**
- **APPLY TO A CLEAN, DRY SURFACE.**
- **APPLY TAPE EVENLY OVER ALL SEAMS. THE WIDER THE TAPE, THE EASIER THE INSTALLATION. USE A FLAT EDGE WHEN APPLYING AND ADD PRESSURE AGAINST THE TAPE TO ACHIEVE THE BEST ADHESION.**
- **WHEN APPLYING TO AN AREA WHERE MOISTURE OR CONDENSATION IS A CONCERN, USE AN ACRYLIC BASED ADHESIVE TAPE.**

Benefits for the Contractor, Architect, and Specifier

Reflectix® is a technologically advanced insulation material ideal for new construction or retrofit installation in commercial, industrial, metal building and post frame buildings. Our products are recognized for their thermal performance, easy installation, versatility, price and environmental friendliness. The demand is greater today than ever for an energy and cost efficient insulation product.

Reflectix® is one of the most versatile building materials on the market today. Reflectix® can be used in the following applications:

CRAWL SPACE

- 1) Reflectix® works as a radon and vapor retarder.
- 2) When properly installed to the bottom of floor joists, Reflectix® will prevent ground moisture from causing dry rot.
- 3) Reflectix® does not support nesting for insects or rodents.
- 4) Reflectix® will never have to be added to or replaced due to a wet crawl space.
- 5) Convenient roll sizes are available.
- 6) There is no need to insulate ducts or pipes installed between Reflectix® and the subfloor.
- 7) Should a tear occur, simply patch with Reflectix® Foil Tape.
- 8) Reflectix® is not hazardous to your health or to the environment.
- 9) Reflectix® is easily installed with a staple gun, utility knife, measuring tape and protective eye wear.
- 10) Reflectix® is great for retrofit on existing crawl spaces.

SIDE WALL

- 1) Reflectix® acts as a vapor retarder when installed on the interior of an exterior wall.
- 2) Our recommended procedure for a side wall application allows passage ways for plumbing and electrical wiring without puncturing the vapor retarder.

BASEMENT WALL

- 1) Reflectix®, including the assembly, use limited floor space being slightly more than 2" from the wall.
- 2) The product R-values are unaffected by humidity.
- 3) Reflectix® is fungus resistant.

- 4) Reflectix® is easily installed and permanent.
- 5) Reflectix® works as a vapor retarder.
- 6) Creating a thermal break, Reflectix® will inhibit or eliminate any dew point condensation problems.

ATTIC

- 1) Reflectix® reduces up to 45% of heat gain through the ceiling, while substantially reducing heat loss as well.
- 2) Reflectix® is easily installed as a retrofit to any existing attic.
- 3) Reflectix® reduces costly damage to attics caused by ice damming and water backflow during the winter months.

POST FRAME, METAL BUILDINGS AND AGRICULTURE

- 1) With Reflectix®, livestock production will substantially increase.
- 2) Reflectix® is ideal for new construction or retrofit of existing structures.

PLUMBING / HVAC

- 1) When using Reflectix®, heating costs will be greatly reduced.
- 2) Eliminate any unnecessary heat loss.
- 3) Pipe wraps will reduce condensation on cold pipes and heat loss on hot pipes.
- 4) Reflectix® water heater wraps greatly reduce recovery time.

RADIANT FLOOR HEATING

- 1) Reflectix® radiates heat in desired directions.
- 2) Reflectix® will increase your efficiency in heating.
- 3) Reflectix® is tough yet pliable
- 4) Reflectix® is easy to install, significantly reducing your installation time.
- 5) Reflectix® works as a vapor retarder.
- 6) May be used to insulate snow melt systems.
- 7) Reflectix® crushing resistance 60 PSI.

AND MANY, MANY MORE!

Testing and Certification

All tests on Reflectix® Insulation are performed at either nationally approved independent laboratories or at leading universities. Tests are performed to current American Society of Testing and Materials (ASTM) Standards when a standard exists. For a copy of any of the actual test reports, call 1 (800) 879-3645.

Nominal Thickness	5/16" (.312)
Weight	1.25 oz./ft ²
Temperature Range	-60° to 180°F
Flame Spread	20*
Smoke Development	30*
Perm. Rating	.02**
Puncture Resistance	60 lb./in.***
Vapor Transmission	.02
Mold and Mildew	No Growth
Emittance	.03
Tensile Strength	3.7 N/mm
Pliability	No Cracking
Hot Surface Performance	Passed

*United States Testing Company, Inc. ASTM Test Method E-84
 ASTM Test E-96 • *FSTM 101 B Method 2031

PRODUCT STANDARDS

Resistance to fungi or bacteria: Reflectix® does not promote the growth of fungi or bacteria.

Specification compliance: Reflectix® is covered under the Federal Minimum Standards Code for reflective insulation (HH-I-1252B) for all H.U.D. and F.H.A. projects.

Reflectix® products have been evaluated by the following:

- I.C.B.O. ES Evaluation Report No. 4933
- B.O.C.A. ES Evaluation Report No. 91-49.1
- S.B.C.C.I. PST & ESI Evaluation Report No. 94102A
- Dade County Evaluation Report No. 03-0514.14
- Los Angeles County Evaluation Report No. RR8099

See Evaluation Reports listed above for allowable values and/or conditions of use concerning material presented in this document.

AVAILABLE TESTING AND CERTIFICATIONS

- Thermal Performance ASTM C236
- Thermal Performance of Wall Systems ASTM C236
- Thermal Performance ASTM C518
- Thermal Performance of Crawl Space ASTM C236
- Thermal Conductivity and Thermal Resistance of Blanket ASTM C518
- Hot Surface Performance ASTM C411
- Heat Transfer (Heat Flow Up, Down, Horizontal) ASTM C236
- Thermal Performance of Reflectix® and Fiberglass in Walls ASTM C236

- Heat Transfer of Air-Handling Ducts with Reflectix®
- Flame Spread and Smoke Density ASTM E84
- Flame Spread and Smoke Density Single Bubble ASTM E84
- Flame Spread and Smoke Density Single Bubble White ASTM E84
- Adhesive Bleeding ICBO Acceptance Criteria
- Flammability FMVSS 302
- Fungus Resistance Mil-Std 810B Method 508
- Pliability Test
- Sound Absorption Test ASTM C423-90a and ASTM E795-83
- Sound Transmission Loss ASTM E90-90 and ASTM E413-87
- Water Vapor Transmission ASTM E96
- Tensile Strength
- Emittance Testing
- Thermal Performance of Water Heater Jackets
- NVLAP Approved Lab Test: Adhesive Bleeding per ICBO Evaluation Service Report # LA 73577
- NVLAP Approved Lab Test: Flame Spread Classification/Smoke Density Developed (Taped Joint Detail) Test Report # LA 62595-1
- NVLAP Approved Lab Test: Flame Spread Classification/Smoke Density Developed (Unslit) Test Report # LA62517-2
- NVLAP Approved Lab Test: Flammability of Interior Materials Report # LA72357-2
- NVLAP Approved Lab Test: Fungus Resistance MIL-STD-810B Method 508 Report # LA 73598
- Southern Building Codes Congress International (SBCCI) Report # PST & ESI 9375
- State of California
- State of California Licensed Insulation Manufacturer
- State of Minnesota: Filed with Minnesota Insulation Standards Program
- State of Wisconsin: Wisconsin Material Approval, Safety and Buildings Division Approval # 920088-1
- Tennessee Technological University Emittance Testing
- Warnock Hersey Professional Services, LTD: Physical Properties Sheet Width, Length, Pliability, Water Vapor Permanence and Aged Water Vapor Permanence Report # 1/92
- Warnock Hersey Professional Services, LTD: Water Vapor Transmission Test ASTM-E96 (Dessicant Method) Report # 1/91

The demand is greater today than ever for an energy efficient, cost effective insulation product.



ENERGY STAR HOME SEALING

EPA recommends sealing the "envelope" that surrounds your living space: the ceiling, outer walls, windows, and floors.

To save on your heating and cooling bill and increase the comfort of your home:

- Add insulation
- Seal air leaks
- Choose ENERGY STAR qualified windows when replacing windows

www.energystar.gov

ENERGY STAR is a program of the U.S. Environmental Protection Agency and the U.S. Department of Energy.



Crawl Space
R-16.89

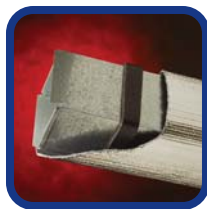

Duct Insulation
R-6.0



Side Walls
R-19.56



Metal Buildings
R-4.91



Basement Walls
R-6.13



Attic

DID YOU KNOW...

- During the summer an attic radiant barrier will reduce heat gain through the ceiling by about 40 percent.
- During the summer only about 20 to 30 percent of the air conditioner load is due to heat gain through the ceiling. Thus the 40 percent reduction reduces the total cooling load of the home by 8 to 12 percent.
- This 8 to 12 percent energy savings occurs only in the cooling season. Recognizing that radiant barriers are also effective during the heating season, the major benefit appears to be in reducing the air conditioning load.
- Annual utility savings estimated between 2 to 10 percent. Payback period is from six to seven years. Source: Florida Solar Energy Center

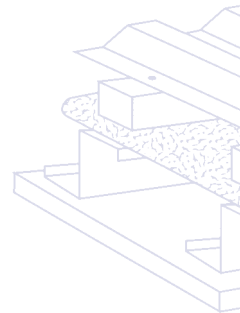
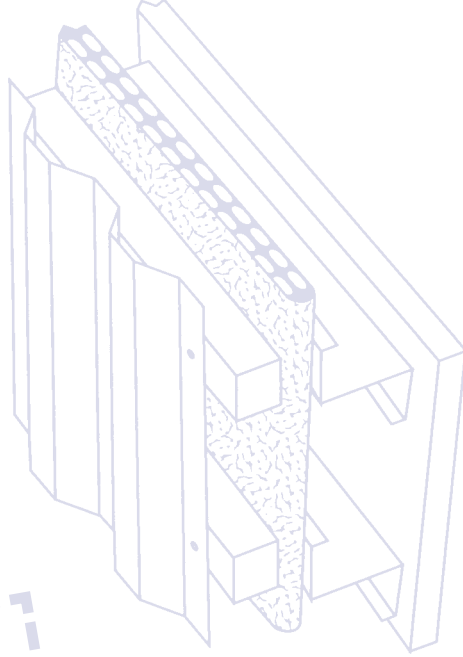

MADE IN THE USA

Still have questions? Needing more information?

Reflectix, Inc. • P.O. Box 108 • Markleville, IN • 46056

Phone: (765) 533-4332 or (800) 879-3645 • Fax: (765) 533-2327

Web: www.reflectixinc.com • E-mail: customerservice@reflectixinc.com

Agricultural • Commercial • Industrial • Residential

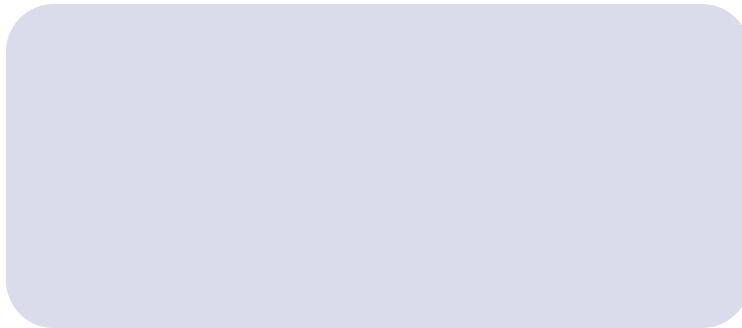

Copyright 2005 Reflectix, Inc. • All Rights Reserved. • F2 Rev. 9-05